

## SUBMITTAL SHEET

JOB NAME	ITEM TAG
JOB LOCATION	PART NUMBER
CONTRACTOR	DATE
ENGINEER APPROVAL	DATE

# TWIN-DISC SILENT WAFER CHECK VALVE - BRONZE DISC

## T-312 with Bronze Disc

Dual spring-loaded discs assure quick, silent closure.

Elastomer seats create a positive seal against backflow.

Can be installed vertically or horizontally, in any orientation.

Durable ductile iron body is designed to install easily between Class 125/150 companion flanges.

The compact body design is lighter and requires less installation space as compared to traditional flanged swing check valves.

The split-disc, center-torsional spring design minimizes pressure drop.



**Pictured:**  
T-312

### Working Pressure, Non-Shock (PSI):

Cold working pressure (CWP):	300 psi.
Saturated steam (WSP):	Not suitable for steam service
Maximum service temperature:	180°F

### MATERIAL SPECIFICATION

PART	MATERIAL	SPECIFICATION
1 Body	Ductile Iron	ASTM A536, 65-45-12
2 Discs (2)	Aluminum Bronze	ASTM B148 UNS C95400
3 Stem	Stainless Steel	AISI 420
4 Spring (2)	Stainless Steel	AISI 304
5 Disc seat	EPDM Rubber	Commercial grade
6 Shaft plugs	Stainless steel	AISI 304
7 Plug seals	EPDM Rubber	Commercial grade
8 Eye bolt (sizes 8"-12")	Plated Carbon Steel	Commercial grade

### DIMENSIONS - Inch

Size	A	B	C	D	Cv
2"	4.02	1.81	2.52	2.13	20
2-1/2"	4.76	2.36	3.07	2.13	37
3"	5.28	2.76	3.70	2.24	64
4"	6.38	3.31	4.61	2.52	180
5"	7.56	4.53	5.71	2.76	490
6"	8.54	5.28	6.69	2.99	740
8"	10.75	7.24	8.82	3.74	1,000
10"	12.91	8.66	10.43	4.25	1,650
12"	16.02	10.24	12.20	5.63	2,600

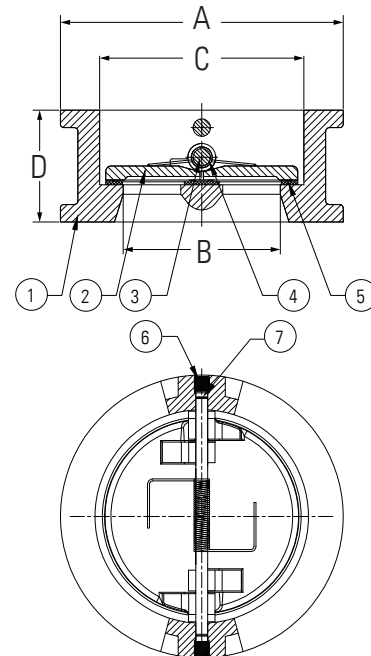

**Pictured**  
**T-312**  
Cut-away

### Standards:

ANSI B16.1: Iron pipe flanges and flanged fittings: Class 125 and 150.

API 594: Check valves: Flanged, lug and wafer.

AWWA C550: Protective interior coatings for valves and hydrants.