

SUBMITTAL SHEET

JOB NAME	ITEM TAG
JOB LOCATION	PART NUMBER
CONTRACTOR	DATE
ENGINEER APPROVAL	DATE

WASHING MASHINE VALVE

Model T-12

5/8" COMPRESSION X 3/4" G.H.T.

Working Pressure, Non Shock (PSI)

Cold working pressure (CWP): 150

Saturated steam (WSP):



Pictured Model T-12

MATERIAL SPECIFICATION

PART	MATERIAL	SPECIFICATION
1 Handle screw	Steel	
2 Handle	Chrome plated brass	ASTM B124 UNS C37700
3 Stem	Chrome plated brass	ASTM B124 UNS C37700
4 Packing	EPDM	
5 Washer	Stainless steel	
6 Bonnet	Chrome plated brass	ASTM B124 UNS C37700
7 Body	Chrome plated brass	ASTM B124 UNS C37700
8 Seat screw	Brass	ASTM B124 UNS C37700
9 Seat	EPDM	
10 Compression ring	Copper	
11 Compression nut	Chrome plated brass	ASTM B124 UNS C37700

DIMENSIONS

Size	A	B
5/8"	1.66	3.67

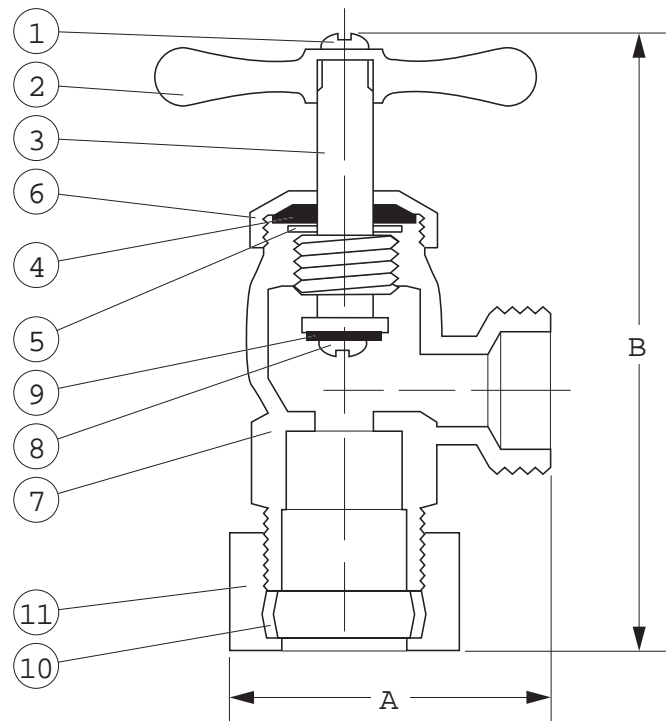

Pictured Model T-12 Cut-away