

## SUBMITTAL SHEET

JOB NAME	ITEM TAG
JOB LOCATION	PART NUMBER
CONTRACTOR	DATE
ENGINEER APPROVAL	DATE

# NO LEAD FORGED BRASS FULL PORT BALL VALVE

## T/S-2001STNL – T/S-2001STNLX

Dezincification-resistant (DZR) forged brass construction resists corrosion from exposure to various water conditions.

Bottom-loaded, blowout-proof stem features a dual-seal PTFE packing and EPDM rubber O-ring design, assuring positive sealing under temperature and pressure extremes.

Standard with stainless steel trim (ball & stem).

Extended stem models (1/2" thru 2") include a locking handle.

Available in nominal sizes 1/2" to 4" in FNPT and sweat connections.

### Working Pressure, Non-Shock (PSI)

Cold Working Pressure (CWP): 1/2" thru 2" – 600 PSI  
2-1/2" thru 4" – 400 PSI

Saturated Steam (WSP): 50 PSI Max



**Pictured:**  
T-2001STNL

**Pictured:**  
T-2001STNLX

### MATERIAL SPECIFICATION

PART	MATERIAL
1 Body	Lead-Free Forged Brass
2 Seats	PTFE
3 Ball	304 Stainless Steel
4 Stem O-Ring	NBR
5 Packing Nut	Forged Brass
6 Stem	304 Stainless Steel
7 Handle Nut w/ nylon insert	Zinc Plated Steel
8 Stem Packing	PTFE
9 Lever Handle (Standard Models)	Zinc Plated Steel
9 Locking Lever Handle (Extended Stem Models)	Zinc Plated Steel
10 End Adapter	Lead-Free Forged Brass
11 Stem Extension Collar	Forged Brass
12 Washer	PTFE

See next page for Cut-Aways & Certifications and Standards

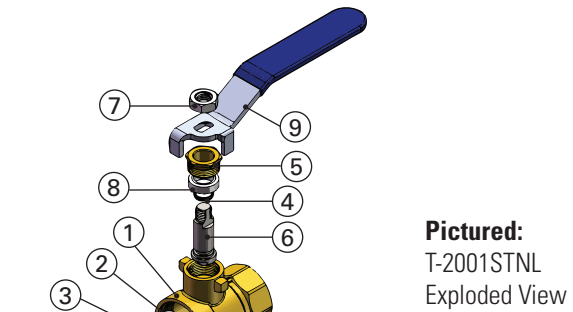

**Pictured:**  
T-2001STNL  
Exploded View

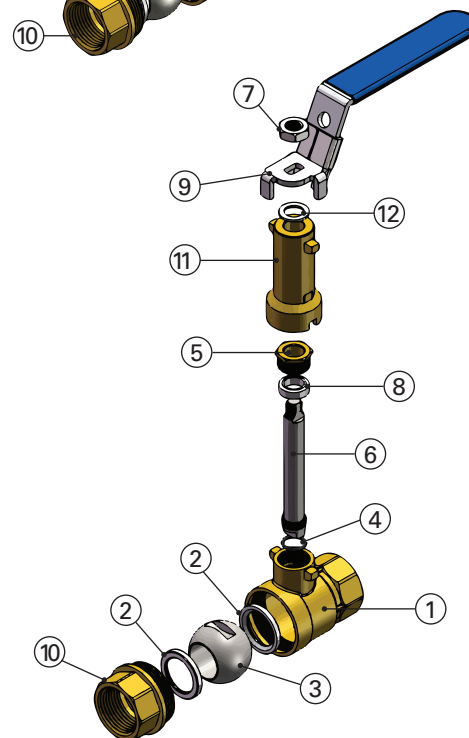

**Pictured:**  
T-2001STNLX  
Exploded View

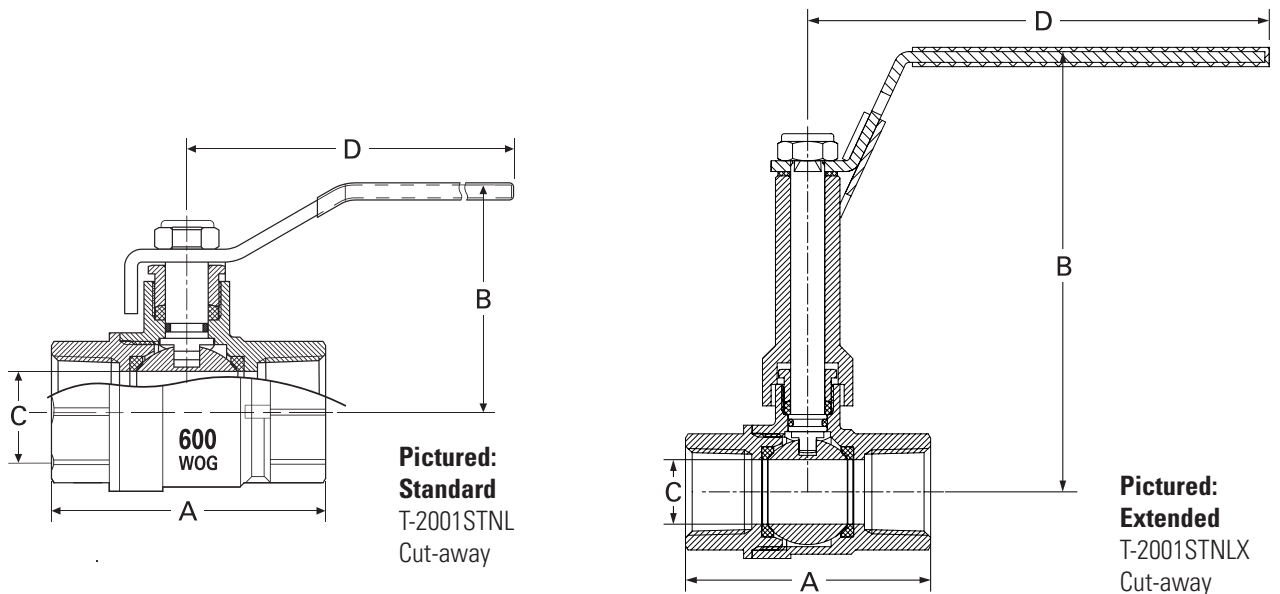

DIMENSIONS							
Size	A		B		C	D	
	FNPT	Sweat	Standard	Extended		Standard	Extended
1/2"	2.24	2.17	1.81	4.04	0.59	3.46	4.25
3/4"	2.52	2.81	2.10	4.57	0.75	4.29	4.80
1"	2.97	3.34	2.25	4.75	0.98	4.29	4.80
1-1/4"	3.44	3.91	2.53	5.16	1.26	5.63	5.31
1-1/2"	3.88	4.46	2.74	5.35	1.57	5.63	5.31
2"	4.29	5.45	3.04	5.65	1.94	6.10	5.31
2-1/2"	5.53	6.42	4.25	-	2.52	7.75	-
3"	6.14	7.15	4.58	-	2.89	8.19	-
4"	7.80	9.57	5.49	-	3.84	8.78	-

**Certifications/Listing:**

- Third-party certified
- NSF/ANSI 61: Drinking water system components - Health effects.
- NSF/ANSI 372: Drinking water system components - Lead content.
- ANSI Z21.15 / CSA9.1: Gas appliance connector valve for 1/2 lb. systems. (1/2" to 2")
- ASME B16.44 / CSA9.4: For use in above ground gas piping systems up to 5 psi. (1/2" to 2")
- ANSI/ASME B16.33: For use in gas piping systems up to 125 psig. (1/2" to 2")
- UL YSDT: LP gas shutoff valve, 125 psi max. (1/2" to 2")
- ASME B16.38: Large metallic valves for gas distribution, 125 psi. (1/2" to 2")
- CSA3.16: Lever operated non-lubricated gas shut-off valve. (1/2" to 2")
- IAPMO/ANSI Z1157: Standard for ball valves.

**Standards:**

- ANSI/ASME B1.20.1: Pipe threads, general purpose, Inch.
- ANSI/ASME B16.18: Cast pressure alloy solder-joint pressure fitting.