

SUBMITTAL SHEET

JOB NAME	ITEM TAG
JOB LOCATION	PART NUMBER
CONTRACTOR	DATE
ENGINEER APPROVAL	DATE

NO LEAD DZR FORGED BRASS PRESS x F1807 PEX BALL VALVE

P-2006NL

Dezincification-resistant (DZR) forged brass resists corrosion from exposure to a wide variety of water conditions.

Bottom-loaded, blowout-proof stem features a dual-seal PTFE packing and stem seat design, assuring positive sealing under a multitude of conditions.

Barbed end is designed for use with Pex (ASTM F876 & 877) and PE-RT (ASTM F 2769).

PEX barbs comply with F1807 copper crimp rings and stainless steel clamps.

Press-to-connect end connection is designed for installation onto ASTM B88 types K, L and M hard-drawn copper tubing.

Press-to-connect end compatible with commercially-available VUS profile jaws.

Available in 1/2" through 2" sizes.

Working Pressure, Non Shock (PSI)

Cold working pressure (CWP): 250 psi* @ 250°F
Saturated steam (WSP): Not suitable for steam service

* **Caution!** Exceeds the temperature and pressure rating of PEX & PE-RT tubing.



Pictured:
P-2006NL

MATERIAL SPECIFICATION			
PART	MATERIAL	SPECIFICATION	
1	Handle nut	Zinc plated steel	Commercial grade
2	Handle	Zinc plated steel	Commercial grade
3	Packing nut	Forged brass	UNS Alloy C36000
4	Packing	PTFE	Commercial grade
5	Body	DZR lead-free forged brass	UNS Alloy C46500
6	Ball	DZR lead-free forged brass or stainless steel	1/2" to 1": UNS Alloy C46500 1-1/4" to 2": AISI 304 SS
7	Seat	PTFE	Commercial grade
8	End adapter	DZR lead-free forged brass	UNS Alloy C46500
9	Stem	Forged brass	1/2" to 1": UNS Alloy C46500 1-1/4" to 2": UNS Alloy C36000
10	Stem seat	PTFE	Commercial grade
11	O-ring	EPDM	Commercial grade

DIMENSIONS - Inch					
SIZE	A	B	C	D	Press Insertion
1/2"	3.11	1.66	0.35	3.82	1-1/8"
3/4"	3.33	1.92	0.53	3.82	1-3/16"
1"	3.78	2.30	0.71	4.41	1-3/16"
1-1/4"	4.39	2.73	0.87	5.20	1-3/16"
1-1/2"	5.09	2.93	1.02	5.20	1-3/8"
2"	6.38	3.54	1.37	6.44	1-9/16"

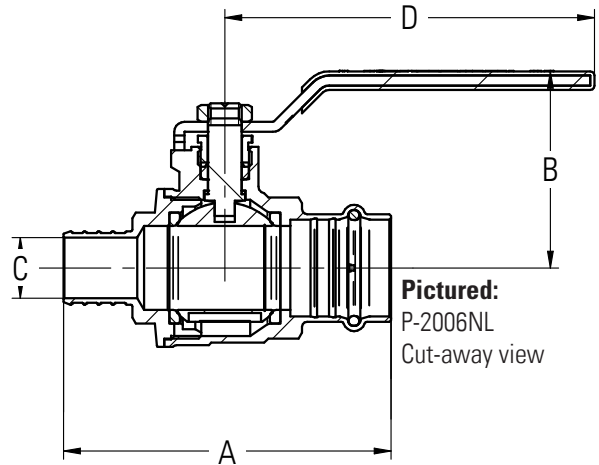

Pictured:
P-2006NL
Cut-away view

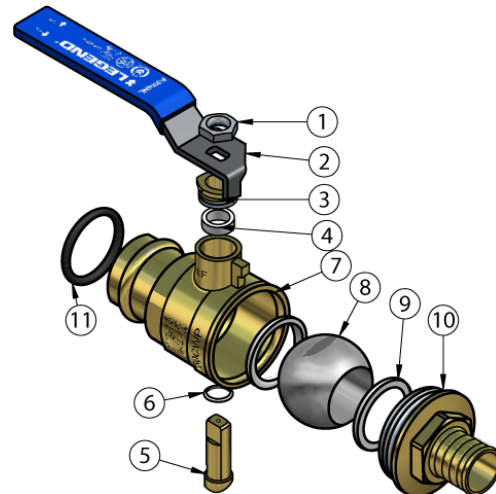

Pictured:
P-2006NL
Exploded view

Certifications/Listings:

Third-Party certified.
NSF/ANSI 14: Plastic piping system components and related materials.
ANSI/NSF 61: Drinking water system components health effects.

Standards:

ANSI/ASME B16.51: Copper and copper alloy press-connect pressure fittings.
ASTM F1807: Metal insert fittings utilizing a copper crimp ring or stainless steel clamps.