

SUBMITTAL SHEET

JOB NAME	ITEM TAG
JOB LOCATION	PART NUMBER
CONTRACTOR	DATE
ENGINEER APPROVAL	DATE



NO-LEAD FULL PORT PRESS BALL VALVE

P-200NL Large Diameter LegendPress®

Press-to-connect end connections are designed for installation onto ASTM B88 types K, L and M hard-drawn copper tubing. See insertion depth chart below.

Deeper tubing sockets at each connection provide extra stability during the pressing process.

Press-type end connections eliminate the need for soldering and brazing, reducing labor and material costs and eliminating the fire hazard associated with the process.

Compatible with commercially-available XL-C* profile rings.

Strip gauge included, to verify a complete press.

Available in nominal sizes 2-1/2" to 4" in the Press x Press configuration.

Working Pressure, Non-Shock (PSI)

Cold Working Pressure (CWP): 2-1/2" to 3" : 300 psi
4" : 250 psi

Saturated Steam (WSP): Not suitable for steam service

Maximum service temp: 2 1/2 to 3" : 250° F @ 180 psi
4" : 230° F @ 180 psi



Pictured:
P-200NL LegendPress®
Large Diameter

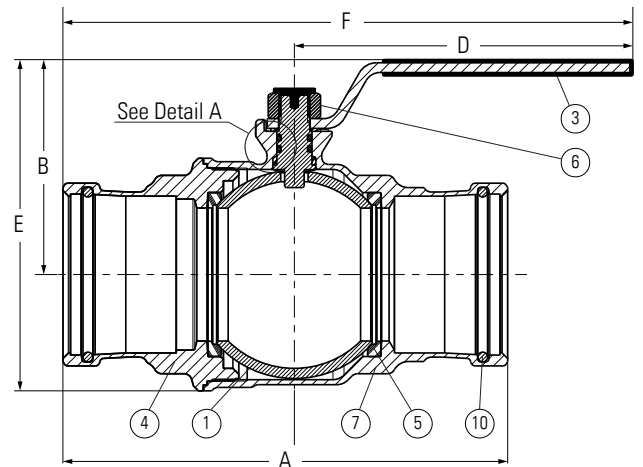

Pictured: P-200NL
LegendPress® (2-1/2" to 4")
Cut-away view

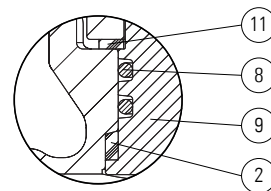

Pictured:
P-200NL
LegendPress®
Stem area - Detail A

MATERIAL SPECIFICATION			
PART	MATERIAL	SPECIFICATION	
1 Ball	Chrome-plated lead-free forged brass	CW510L	
2 Anti-friction thrust washer	PTFE	Commercial grade	
3 Handle	Dacromet coated steel	ASTM A510 UNS G10060	
4 End adapters	Lead-free forged brass	CW510L	
5 Seats (2)	PTFE	Commercial grade	
6 Handle Nut	Dacromet coated steel with PVC resin lock	ASTM A510 UNS G10060	
7 Body	Lead-free forged brass	CW510L	
8 Stem	Stainless steel	AISI 303	
9 Stem O-rings (2)	Flouroelastomer (Viton)	Commercial grade	
10 Socket O-rings (2) [1 per socket]	EPDM	Commercial grade	
11 Anti-friction washer	PTFE	Commercial grade	

*XL-C is a registered trademark of Viega

DIMENSIONS						
Size	A	B	C	D	E	F
2-1/2"	8.24	4.04	2.56	6.82	6.06	11.16
3"	8.96	4.33	3.15	6.82	6.67	11.48
4"	11.24	5.03	3.94	7.35	8.15	12.67

See the P-200NL LegendPress® submittal sheet for 1/2" to 2" sizes.

Certifications/Listing:

Third party certified
ANSI/NSF 61: Drinking water system components - Health effects.

Standards:

ANSI/ASME B16.51: Copper and copper alloy press-connect pressure fittings.
MSS SP-110 - Valve body construction only.

LegendPress® Tubing Insertion Depth

Nominal Tubing Size:	2-1/2"	3"	4"
Insertion Depth: In.	2-3/16"	2-1/4"	2-3/8"