

## SUBMITTAL SHEET

JOB NAME	ITEM TAG
JOB LOCATION	PART NUMBER
CONTRACTOR	DATE
ENGINEER APPROVAL	DATE

# LEGENDPRESS® CSW PRESS FITTING SYSTEM

## Carbon Steel Water Fittings

Press-to-Connect end connections reduce labor costs and increase production.

Approved for non-potable water applications, like hydronic heating & cooling, and fire sprinklers.

Designed for installation onto ASTM A53 Schedule 10 to Schedule 40 carbon steel pipe. (Hydronic applications)

Sprinkler applications require Schedule 10 or Schedule 40 steel sprinkler pipe in accordance with NFPA 13.

Fittings are approved for indoor or outdoor use and above or below ground installations. Per code, local inspector approval must be granted prior to installation below ground.

Compatible with commercial pressing tools and jaws for carbon steel press. See IOM for list.

Available in nominal sizes 1/2" to 2" in various configurations.

### Working Pressure, Non-Shock (PSI)

Cold Working Pressure (CWP): 200 psi Max

Operating temperature range: 0°F to 250°F

Vacuum-rated to 29.2 in/Hg at 68°F

Saturated Steam: 5 psi Maximum

### MATERIAL SPECIFICATION

PART	MATERIAL
1 Body	Zinc Coated Carbon Steel
2 O-Ring	EPDM
3 Spacer	Chrome Plated Copper
4 Grip Ring	420 Stainless Steel

### PRESS FITTING INSERTION DEPTH

Nominal Pipe Size:	1/2"	3/4"	1"	1-1/4"	1-1/2"	2"
Insertion Depth (in)	1-1/8"	1-1/4"	1-3/8"	1-7/8"	1-7/8"	2"

### Certifications/Listings:

Third-Party certified.

FM Class 1920: Pipe Couplings and Fittings for Above Ground Fire Protection Systems.

ANSI/CAN/UL 213: UL Standard for Rubber Gasketed Fittings for Fire Protection Service.

UL 852: Standard for Metallic Sprinkler Pipe for Fire Protection Service.

ULC/ORD C199S: Light Wall Steel Pipes for Sprinkler Systems for Fire Protection Service.

Uniform Mechanical Code (UMC)

IAPMO/ANSI/CAN Z1117-22: Standard for press connections.

### Standards:

ANSI / ASME B1.20.1: Standard Specification for Pipe Threads, General Purpose (Inch)



**Pictured:  
CSW Tee**

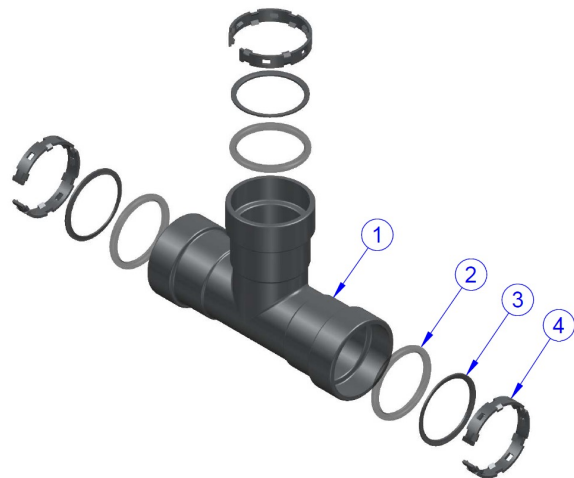

**Pictured:  
CSW Tee  
Exploded View**