

Insta-Loc II™ No Lead and DZR Push-to-Connect Valves and Fittings

Application:

Typically installed on lead-free potable water plumbing distribution systems. Insta-Loc II™ valves and fittings are constructed with DZR brass alloy, and allow quick and easy, yet strong and durable connections of ASTM F876 and F877 compliant PEX, ASTM D2846 compliant CPVC or ASTM B88 compliant hard drawn or soft annealed copper tubing without sweating, solvents or crimp-rings.

Note 1: They are not suitable for use on PEX tubing with an oxygen barrier on the outer layer, or composite PEX-AL-PEX tubing.

Note 2: Before installing onto copper tubing, allow the tubing to completely cool following any soldering or brazing process.

Installation Instructions:

1. Cut tubing to desired length, accounting for the insertion depth of **15/16"** for 1/2," **1-1/8"** for 3/4 and **1-5/16"** for 1" nominal tubing size end connections.
2. Ensure that the tubing end is round, the cut is square and that no scratches, dents or burrs are present. Major imperfections in the tubing end may damage the o-ring or prevent a proper seal resulting in a leak and voiding the warranty.
3. Using a permanent marker and measuring tool, make an **insertion depth reference mark** onto the tubing, at the applicable depth:

Nominal tubing size:	Insertion depth:
1/2"	15/16"
3/4"	1-1/8"
1"	1-5/16"

The mark serves as visual reference to a completely-inserted tubing end. **DO NOT SKIP THIS STEP!**

4. No additional lubricant is necessary, nor should be applied to the sockets however, the tubing end may be rinsed with potable water prior to insertion into the socket.

5. **If you are connecting PEX tubing, go to step six.** If you are connecting copper (drawn temper-hard or annealed-soft) or CPVC tubing, first remove the pre-installed insert stiffener (see exploded-view drawing; part number seven) by firmly grasping it, and pulling straight out, then insert the marked tubing end into the Insta-Loc II™ fitting or valve. Push the Insta-Loc II™ fitting or valve onto the tubing until it stops, which should correspond to the mark on the tubing, verifying the correct insertion depth. Some resistance is normal.

6. Guide the insert stiffener (pre-installed in each Insta-Loc II™ socket) into the inside diameter of the marked PEX tubing, as you engage the tubing into the socket connection. Push the Insta-Loc II™ fitting or valve onto the tubing until it stops, which should correspond to the mark on the tubing, verifying the correct insertion depth. Some resistance is normal.

7. The Insta-Loc II™ valve or fitting can be rotated to allow for proper alignment once installed on the tubing. A gentle pull will indicate if the connection is satisfactory. Absolutely NO lateral movement should occur! Any lateral movement could indicate an improper insertion depth - repeat steps five or six, depending on the type of tubing you're connecting.

8. Support and secure the tube per local codes and be sure to prevent any stress on the Insta-Loc II™ connections in all directions. **WARNING!** Place all tubing support types at least one inch away from the Insta-Loc II™ socket connection. Thermal contraction and expansion of the tubing may cause movement, which could allow support and release collar contact, resulting in unwanted tubing release and leakage.

9. After the system is complete; perform a pressure test and inspect all connections for leakage. **All Insta-Loc II™ connections have a maximum working pressure of 200 psi and a maximum working temperature of 250° Fahrenheit**, however PEX and CPVC tubing may have a lower temperature rating and therefore limit the maximum temperature of the system.

Installation is complete.

Removal:

1. **IMPORTANT!** Relieve system pressure prior to removal of any Insta-Loc II™ valve or fitting!
2. Place the correct-size (1/2", 3/4" or 1") release tool over the tubing, with the tool's groove facing the Insta-Loc II's socket connection.
3. Firmly push and hold the release tool against the valve's or fitting's release collar. The release collar will move inward, releasing the grip ring from the tubing (See part numbers two and three in the exploded-view drawing).
4. Separate the Insta-Loc II™ valve or fitting from the tubing, by pulling the tubing out of the socket. Remove the release tool from the tubing.
5. Prior to re-use, inspect the Insta-Loc II's™ connection components. **NEVER** re-use an Insta-Loc II™ valve or fitting that has damaged socket components! **NOTE:** If PEX tubing is removed, the insert stiffener may remain in the Insta-Loc II's™ socket. If it does, the stiffener must NOT be removed (as in re-use of the Insta-Loc II™ onto copper or CPVC tubing). Forcibly removing the stiffener **after** PEX tubing has been removed may result in damage to the grip ring. Therefore, the Insta-Loc II™ valve or fitting must NOT be re-used onto copper or CPVC, only PEX.
6. Prior to re-inserting, inspect the tubing for damage or debris. As described in step two of the installation instructions, major imperfections of the tubing end are unacceptable. Only square-cut, clean, round, undamaged tubing ends are suitable for installation.

Release tools are re-usable. Discard any damaged tools.

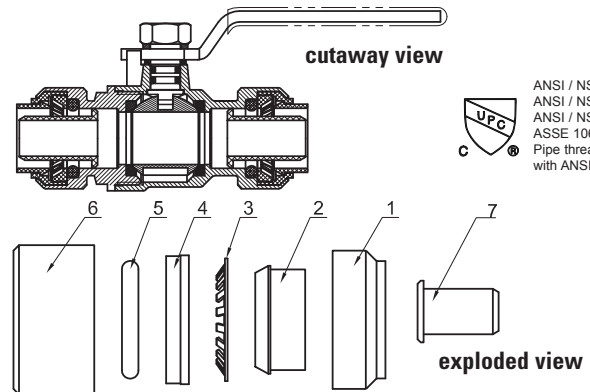

ANSI / NSF 61-8 and 61-9
 ANSI / NSF Annex G
 ANSI / NSF 14
 ASSE 1061
 Pipe threaded configurations comply with ANSI / ASME B1.20.1

NO	PART	MATERIAL	SPECIFICATION
1	RETAINER RING	POLYACETAL RESIN	CELCON M90
2	RELEASE COLLAR	POLYACETAL RESIN	CELCON M90
3	GRIP RING	STAINLESS STEEL	AISI 304
4	GUIDE RING	POLYACETAL RESIN	CELCON M90
5	O-RING	EPDM RUBBER	COMMERCIAL GRADE
6	FITTING/VALVE BODY	LEAD FREE DZR BRASS	COMMERCIAL GRADE
7	INSERT STIFFENER	POLYSULFONE RESIN	COMMERCIAL GRADE

Operation, Maintenance and Adjustment:

- Insta-Loc II™ valves and fittings valves and fittings are certified and/or meet the following Standards for performance, dimensional and material requirements: ASSE 1061, ANSI / NSF 61, ANSI / NSF 61 Annex G and ANSI / NSF 14. All Insta-Loc II™ valves and fittings comply with the California, Vermont and Maryland lead-free plumbing laws and pending Federal Public Law 111-380, which becomes effective January 4th, 2014. They are third-party certified by UPC-IAPMO.
- Insta-Loc II™ valves and fittings are maintenance-free and will provide years of trouble-free service. As a matter of good practice, inspect the entire system annually for signs of leakage.
- Do not hang items on the secured tubing runs, as this may cause excessive stresses on the connections.
- No adjustments are necessary. After the tubing has been properly supported and secured and the system has been pressure tested, it is recommended that the valves or fittings NOT be rotated.
- Lubrication of the tubing ends prior to insertion is not necessary. Lubrication of the o-ring is not recommended. The o-rings are pre-lubricated at the factory with ANSI/NSF 61 approved silicone-based grease. Use care when handling the valves and fittings. Do not drop them or place your fingers inside the ends as the stainless steel grip-ring is sharp and may cause injury.

Legend Valve • 300 N. Opdyke Road • Auburn Hills, MI 48326

phone: (800) 752-2082 fax: (800) 835-4457

web: www.legendvalve.com - email: service@legendvalve.com