

SUBMITTAL SHEET

JOB NAME	ITEM TAG
JOB LOCATION	PART NUMBER
CONTRACTOR	DATE
ENGINEER APPROVAL	DATE

LEAD-FREE FLARE X MNPT ADAPTER

T-4100NL

Designed and manufactured for underground water service installations only.

Available in nominal sizes 3/4" through 2".

Specifications:

Manufactured in compliance with the latest version of AWWA C800, for high pressure.

MATERIAL SPECIFICATION		
PART	MATERIAL	
1 Body	Lead-free Cast Bronze	
2 Flare nut	Cast Bronze	

DIMENSIONS - Inch			
Size	A	B (Flat to Flat)	Item No.
3/4"	3.26	1.53	313-004NL
1"	3.89	1.84	313-005NL
1-1/4"	4.08	2.37	313-006NL
1-1/2"	4.80	2.91	313-007NL
2"	5.69	3.54	313-008NL

Certifications/Listings:

Third-party certified.
ANSI/NSF 61: Drinking water system components - Health effects.
ANSI/NSF 372: Drinking water system components - Lead content.

Standards:

AWWA C800: Underground service line valves and fittings.
ANSI/ASME B1.20.1: Pipe threads, general purpose, Inch.



Pictured:
T-4100NL

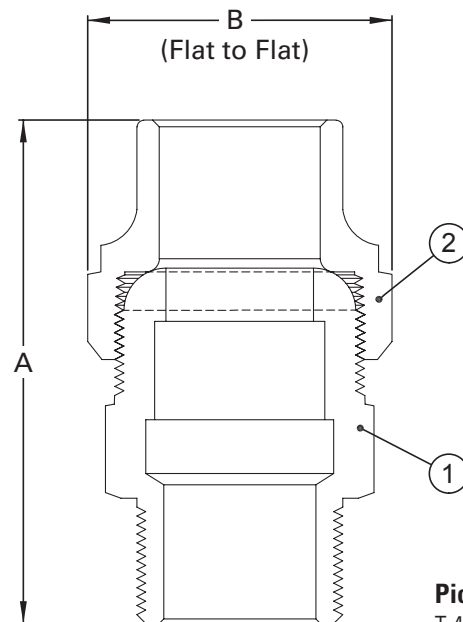

Pictured:
T-4100NL
Cut-away