

## SUBMITTAL SHEET

JOB NAME	ITEM TAG
JOB LOCATION	PART NUMBER
CONTRACTOR	DATE
ENGINEER APPROVAL	DATE

## NO LEAD FULL PORT BALL VALVE

### T/S-1001NL and T-1001LDNL

- Durable lead-free forged brass body.
- Bottom-loaded blowout-proof stem.
- Maintenance-free dual O-ring stem seal.

Available in female pipe threaded sizes 1/8" - 4" and female sweat tubing sizes 1/2" - 4".

#### Working Pressure, Non Shock (PSI)

Cold working pressure (CWP): 600 psi (1/8" - 2"); 400 psi (2-1/2" - 4")  
Saturated steam (WSP): 150 psi (all sizes)



**Pictured:**  
T-1001NL

MATERIAL SPECIFICATION			
PART	MATERIAL	SPECIFICATION	
1	Handle nut	Dacromet coated steel, tamper-evident	AISI 10060
2	Handle	Dacromet coated steel with vinyl sleeve	AISI 10060
3	Anti-friction washer	PTFE	Commercial grade
4	Stem O-rings (2)	Viton	Commercial grade
5	Thrust washer	PTFE	Commercial grade
6	Stem	Lead-free forged brass	UNS Alloy C28500
7	Ball	Lead-free forged brass	UNS Alloy C28500
8	Seats (2)	PTFE	Commercial grade
9	Body	Lead-free forged brass	UNS Alloy C28500
10	End adapter	Lead-free forged brass	UNS Alloy C28500
11	Locking Device*	Dacromet coated steel	AISI 10060

\*Not shown

DIMENSIONS - Inch						
Size	A (IPS)	A (CXC)	B	C	D	CV**
1/8"	1.54	-	1.02	0.31	1.66	5.00
1/4"	1.62	-	1.02	0.31	1.66	7.62
3/8"	1.77	-	1.28	0.39	3.01	7.74
1/2"	2.08	2.32	1.46	0.59	3.01	14.68
3/4"	2.36	3.15	1.89	0.79	3.70	28.43
1"	2.91	3.82	2.05	1.00	3.70	56.04
1-1/4"	3.30	4.31	2.24	1.26	3.70	113.24
1-1/2"	3.74	5.00	2.75	1.57	5.33	161.77
2"	4.25	6.10	3.07	1.97	5.33	243.81
2-1/2"	5.75	7.00	4.01	2.28	6.81	277.32
3"	6.30	8.03	4.33	2.68	6.81	310.83
4"	8.15	7.19	5.12	3.50	7.32	532.68

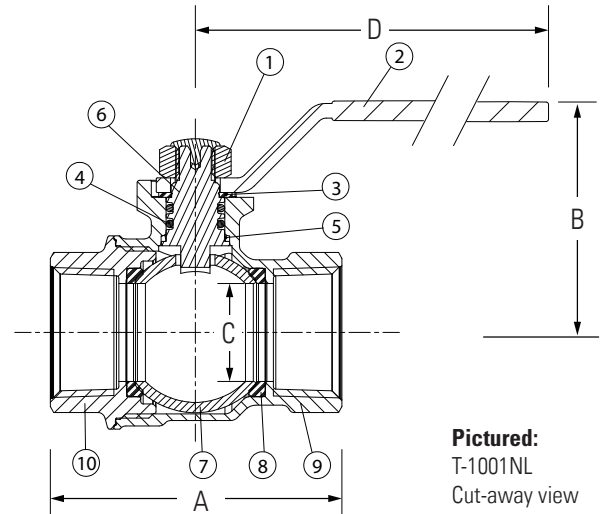

**Pictured:**  
T-1001NL  
Cut-away view

#### Certifications/Listings:

- Third-party certified.
- ANSI/NSF 61: Drinking water system components - Health effects.
- ANSI Z21.15 / CSA 9.1: Gas appliance connector valve for 1/2 lb. systems. (1/4" - 2" NPT)
- ASME B16.44 / CGA CR91-002: For use in above ground gas piping systems up to 5 PSI. (1/4" - 2" NPT)

- UL MHKZ: Manual shutoff valve, 125 psi max. (1/2" - 2" NPT)
- UL YQNZ: Compressed gas shutoff valve, 125 psi max. (1/2" - 2" NPT)
- UL YRBX: Flammable liquid shutoff valve. 125 psi max. (1/2" - 2" NPT)
- UL YRPV: Gas shutoff valve, 125 psi max. (1/2" - 2" NPT)
- UL YSDT: LP gas shutoff valve, 125 psi max. (1/2" - 2" NPT)

#### Standards:

- MSS SP-110
- ANSI/ASME B1.20.1: Pipe threads, general purpose, Inch.
- ANSI/ASME B16.18: Cast Pressure alloy solder-joint pressure fittings.

\*The CV Factor is the gallons of water per minute passed through the valve with a 1 psi pressure drop.